

optional  
stainless steel

# MODEL EK6

## BACKLASH FREE ELASTOMER COUPLINGS

Series  
10 - 800

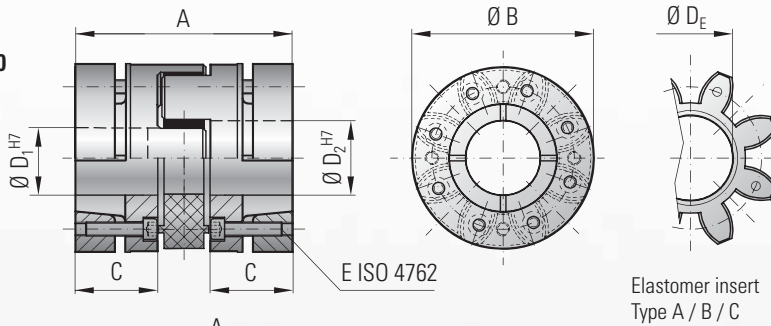

Series  
2500 - 9500

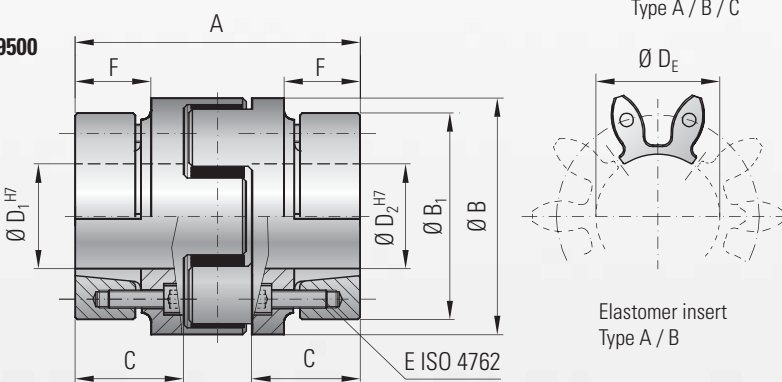

with conical clamping ring

**Properties:**

- high clamping forces
- concentrically machined hubs
- vibration damping
- electrically isolating
- backlash free
- press fit design
- axial mounting possible

**Material:**

Clamping hub and clamping ring: up to series 450 high strength aluminum, series 800 and up steel  
Elastomer insert: precision molded, wear resistant, and thermally stable polymer

**Design:**

Two coupling hubs are concentrically machined with curved jaws

**Speeds:** See table below

\*Please contact R+W  
ISO 2.5 balance grade available

**Tolerance:**

Overall clearance between shaft and hub 0.01 to 0.05 mm

**Optional:** Outward facing clamping screws

Model EK 6	Series																													
	10			20			60			150			300			450			800			2500			4500			9500		
Type (Elastomer insert)	A	B	C	A	B	C	A	B	C	A	B	C	A	B	C	A	B	C	A	B	C	A	B	C	A	B	C	A	B	C
Rated torque (Nm) $T_{KN}$	12.6	16	4	17	21	6	60	75	20	160	200	42	325	405	84	530	660	95	950	1100	240	1950	2450	5000	6200	10000	12500			
Max. torque (Nm) $T_{Kmax}$	25	32	6	34	42	12	120	150	35	320	400	85	650	810	170	1060	1350	190	1900	2150	400	3900	4900	10000	12400	20000	25000			
Overall length (mm) A	42			56			64			76			96			110			138			177			227			282		
Outside diameter (mm) B/B <sub>1</sub>	32			43			56			66			82			102			136.5			160 / 158			225 / 208			285		
Mounting length (mm) C	15			20			23			28			36			42			53			70			90			112		
Inside diameter range H7 (mm) D <sub>1/2</sub>	6 - 16			8 - 24			12 - 32			19 - 35			20 - 45			28 - 55			32 - 80			40 - 95			50 - 130			60 - 170		
Inside diameter of elastomer (mm) D <sub>E</sub>	14.2			19.2			26.2			29.2			36.2			46.2			60.5			80			111			145		
Clamping screw (ISO 4762)	3x M3			6x M4			4x M5			8x M5			8x M6			8x M8			8x M10			10x M10			10x M12			10x M16		
Tightening torque of the clamping screw (Nm) E	2			3			6			7			12			35			55			60			100			160		
Distance (mm) F																			51			66			80					
Moment of inertia per Hub (10 <sup>-3</sup> kgm <sup>2</sup> ) J <sub>1</sub> /J <sub>2</sub>	0.004			0.015			0.05			0.1			0.3			0.85			9.2			31.7			135.7			469.2		
Approx. weight (kg)	0.08			0.12			0.3			0.5			0.9			1.5			9.6			15			35			73		
Speed standard (min <sup>-1</sup> )	20,000			19,000			14,000			13,000			10,000			9,000			4,000			3,500			3,000			2,000		
*Speed balanced (10 <sup>3</sup> min <sup>-1</sup> )	53	63	40	45	60	35	31	31	25	22	26	18	22	26	16	16	17	12	13	13	8	10	10		8	8		6.5	6.5	

Information about static and dynamic torsional stiffness as well as max. possible misalignment see page 5

1 Nm = 8.85 in lbs

Lateral access holes for screw tightening are not necessary with EK6 couplings. The unique assembly screw design (shown at right) allows for easy axial mounting and dismounting of the coupling hub

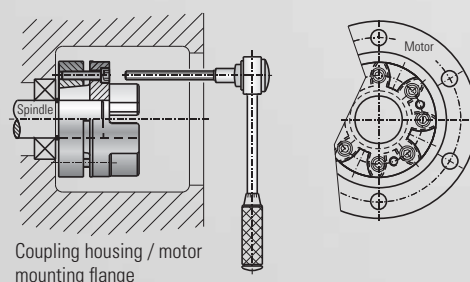

**Ordering example**

EK6 / 60 / A / 19.05/24 / XX

Model	_____
Series	_____
Type Elastomer insert	_____
Bore Ø D1 H7	_____
Bore Ø D2 H7	_____
Non standard e.g. anodized	_____

All data is subject to change without notice.